

WINCH



WINCH FOR LIFTING PERSONNEL OR MATERIALS

The Globestock WINCH is specifically certified for the lifting of both personnel and materials. It is a personnel winch that may also be used for load lifting.



The anti-run braking mechanism means that, if the winding arm is released during lifting, the winch automatically locks, holding the person / load steady until the handle is rotated again by the operator.

The 1:8.9 gear ratio makes personnel lifting easy, and delivers 50 mm of rope retrieval per rotation.

May be mounted to various anchorages, including the SENTRY Tripod and XTIRPA range.

- **Up to 250 kg MWL**
- **Heavy duty**
- **Anti-run brake**
- **Up to 40 m rope**
- **Galvanised or stainless steel rope**

WINCH fitted to a SENTRY Tripod

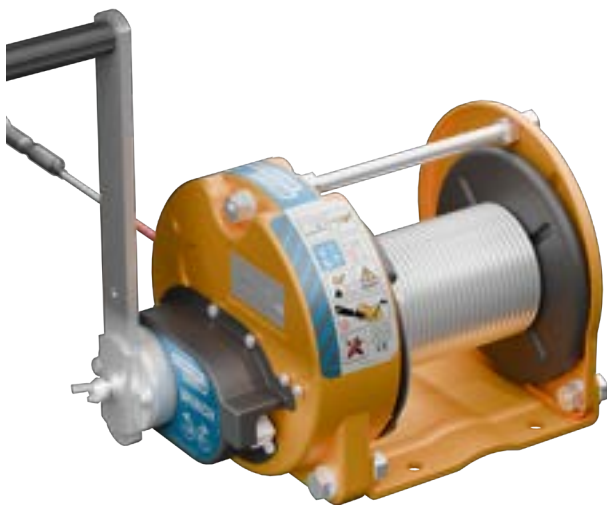
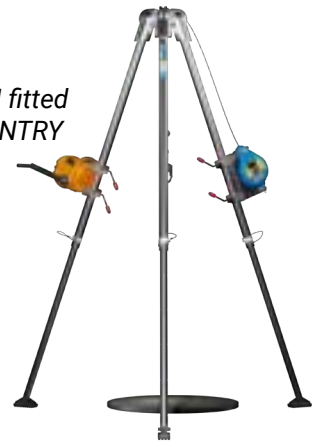

Product Code	MWL	Weight (Approx.)	Max. Rope Length	Rope Kit
GSE070-20G	250 kg	20.5 kg	20 m	Galvanised steel rope & alu karabiner
GSE070-40G		22 kg	40 m	
GSE070-40SSK	200kg	22 kg	40 m	Stainless steel rope & alu karabiner

SETTING UP THE GLOBESTOCK WINCH

GLOBESTOCK
SAFETY



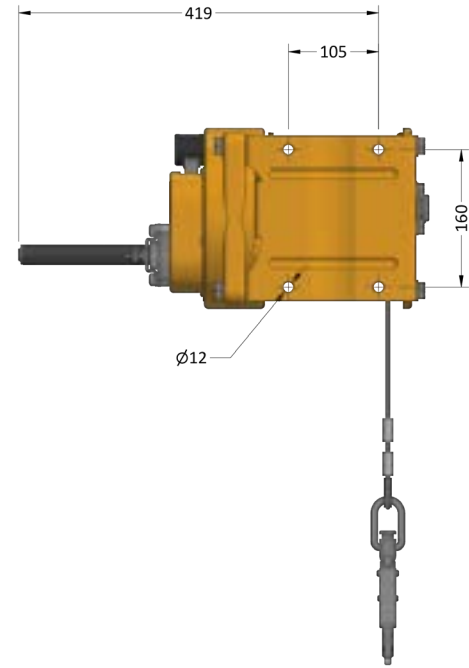
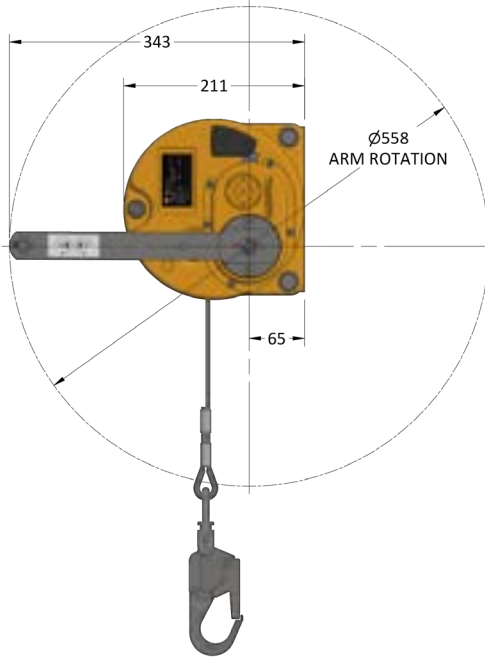
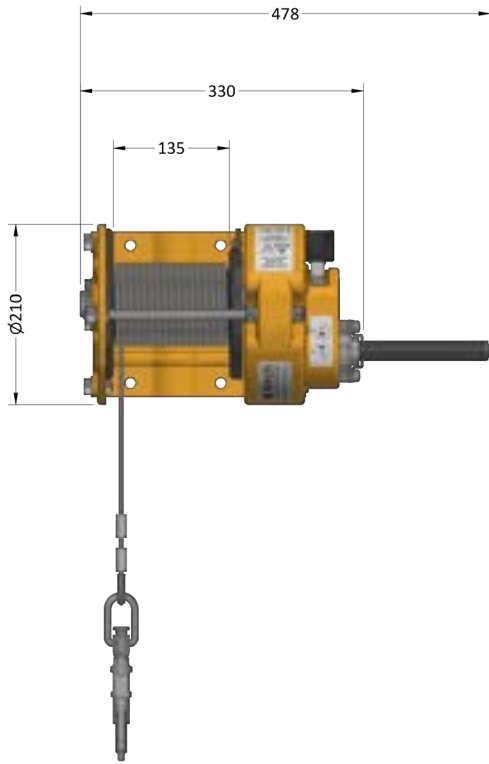

WINCH ACCESSORIES



WINCH Bracket
(for XTIRPA anchorages)
GSE200WBX



Winch Bracket Assembly x2
(for SENTRY Tripod)
GSE200WBK



Holdall bag
GSE-H/ALL



250 kg Lifting Pulley
GSE070250USP