

PORTABASE[®]

➤ Assembly & Operation Guide

Contents

Correct Operation	4	ATEX	20
Intended Use		ATEX	
Inspection Prior to Initial Operation		ExVeritas Certification	
Inspection Before Starting Work		Classification [Zone 2]	
Maximum Capacity		Spark Formation	
Temperature Range		Static Electricity	
Notes for Correct Operation		Inspection, Maintenance & Repair	
Warning			
Allowable Rotation			
Fall Protection Applications	9	Assembly Instructions	22
Fall Protection		H Base	
Additional Notes for Correct Operation		Counterbalance	
Warning		Trailer Hitch	
IRATA			
Inspection & Maintenance	18	Variants & Options	32
Regular Inspections		Dimensions	33
Maintenance & Repair		Quality & Safety	36
Storage & Transportation		Regulations, Standards & Directives	
		Accreditations	
		Conformité Européenne [CE]	
		Testing	
		Language	
		Product IPR	
		Product Labelling	38
		Inspection Record	42

Lightweight. Portable. **Safe.**

Please read the following instructions and guidance notes carefully, before using or operating the system.

They contain important information about how to handle and use the system in a safe and efficient way, avoiding danger, reducing repair costs and downtime, and increasing the reliability and lifespan of the system.

They apply for:

- Operation, including preparation, troubleshooting during operation and cleaning
- Maintenance, inspection, repair
- Transportation

It is the responsibility of the end user to adhere to the Health & Safety and accident prevention standards and legislation valid in their respective countries and any regions in which the system is being used. It is also incumbent on the user or competent person to ensure that anyone working with the equipment has the necessary medical and physical capabilities. A rescue plan also needs to be in place in the event of an emergency that could occur during the work. This document should form part of the overriding Risk Assessment and Method Statement required for each lift and access event.

➤ Correct Operation

Intended Use

This product is designed, tested and intended to be used for the lifting of goods, the lifting of personnel, rope access work or for providing a safety anchor for the prevention of falls as part of a personal fall protection system. (PFAS). The use of our products for these multiple applications is consistent with the products design, notwithstanding pre-user inspections and mandatory inspections by a competent or qualified person, determined by local regulations.

This product forms one part of a lifting system, the other part being a REID Lifting Davit. Before using the equipment, both Assembly & Operation Guides must be read.

Lifting of Goods: Each product will be marked with a Working Load Limit (WLL). The WLL is specifically intended as a maximum limit for the lifting of goods, materials and equipment and includes safety factors.

Lifting of Personnel: For the lifting of personnel REID Lifting will reduce the WLL by half, thereby increasing the safety factor of the product. As for lifting goods, materials and equipment, the lowest rated element of the system always takes precedent. Associated equipment used for lifting personnel must be rated accordingly. It is the employers' responsibility to ensure this is the case. For example, a winch must be personnel rated and where necessary, meet applicable standards and regulations for the country of use.

Fall Protection Anchor: In most cases (subject to labelling and instructions for use for specific products confirming this) REID lifting products are tested and meet the requirements of fall protection standards and regulations, including EN795:2012 and IRATA ICOP as referenced in our Instructions for Use. The WLL on the product is of no relevance to fall protection standards and requirements and the user should refer to the specific sections of the instructions for use, for detailed information. For example; EN795 requires that anchors that form part of a personal fall protection system are capable of withstanding a minimum 12kN static load for a single user and a further 1kN for each additional user. IRATA requires a 15kN static load. Additionally, fall protection systems are required to pass a series of dynamic performance tests. REID Lifting products will, where applicable be marked with the rating for fall protection. Safety factors will be higher than those for lifting and forces will be limited by the use of personal fall protection equipment, including load limiting devices such as shock absorbers or self-retracting lifelines that reduce impact forces, typically to a maximum of 6kN per user as required by law.

Note: some jurisdictions may not allow the same equipment to be used for lifting of materials and as a component of a PFAS. Some employers may also prefer to keep such equipment distinctly separate. If this is the case, we would recommend that the equipment is labelled accordingly Check your local regulations before putting equipment to use and designate accordingly.

It is expected that all users of this product have the necessary medical and physical capabilities, are fully trained and deemed competent in its safe assembly and use. We would remind users of the requirement to ensure that work is properly planned, risk assessments carried out and as required, method statements for carrying out work provided.

Where required the owner/user of the equipment should ensure that a qualified person has been consulted in respect of the need for structural validation, for example (but not limited to); calculating imposed loads for the safety of ground, floor or roof structures during lifting operations.

Inspection Prior to Initial Operation

Each product must be inspected prior to initial operation by a competent person to ensure that the structure is safe and that it has not been damaged by incorrect assembly, transport or storage.

Inspection Before Starting Work

Before starting work, the product assembly and all load-bearing components should be checked for visual defects as per the inspection checklist on page 18.

Maximum Capacity

Goods Lifting: This product is designed to lift and lower loads up to its rated capacity. Do not exceed the capacity indicated on the system.

Personnel Lifting: When lifting people, the overall load limit is reduced by half to provide an increased safety factor. The maximum capacity permitted by the personnel winch/accessory used in conjunction with the product also needs to be considered.

Please refer to the tables for information on capacities and required amounts of counterweight. The capabilities and counterweight stated in the tables apply to standard range systems only. If you are unsure about the system, consult the serial labels information on page 38 or consult your supplier

Temperature Range

This product can be operated in ambient dry temperatures between -20°C (-4°F and 131°F). Consult your supplier in case of extreme working conditions. If used in sub-zero and wet conditions, fall arrest appliances characteristics may change.

PORTABASE® Maximum Capacity [kg]					
Max Radius		800mm		1000mm	
Part Code	Description	Goods Lifting	Personnel Lifting	Goods Lifting	Personnel Lifting
PBHB00001	H Base	600kg	300kg	x	x
PBCB00001	Counterbalance	600kg	300kg	500kg	250kg
PBCB00003	Counterbalance Trailer Hitch	450kg	225kg	360kg	180kg

For fall protection applications see page 9.

➤ Correct Operation

Basket Counterweight required to lift load [kg] [Goods and Personnel lifting only]												
WLL	Goods	100kg	150kg	200kg	250kg	300kg	350kg	400kg	450kg	500kg	550kg	600kg
	Personnel	50kg	75kg	100kg	125kg	150kg	175kg	200kg	225kg	250kg	275kg	300kg

Minimum Weight Requirement

Radius	800mm	80kg	120kg	160kg	200kg	240kg	280kg	320kg	360kg	420kg	460kg	500kg
	900mm	100kg	140kg	180kg	240kg	280kg	320kg	360kg	420kg	460kg	500kg	x
	1000mm	100kg	160kg	200kg	260kg	300kg	360kg	410kg	460kg	520kg	x	x

Notes for Correct Operation

- Read in conjunction with the instructions for use of your chosen REID Lifting Davit.
- We recommend the use of load-sensing or overload protection devices on all lifts.
- The risk assessment and method statement must consider any factors that might apply additional loading to the system during lifting operations.
- Suitable, appropriately rated winches, hoists and bracket plates must be used for all applications.
- Take care when transporting and storing the system to avoid damage.
- Assemble only as instructed (ensure all bolts and pins are present and fitted correctly as per instructions).

- We recommend that appropriate PPE are worn when using the equipment.
- Attach the hoist to the dedicated lifting points only, making sure it is attached in a way that does not expose the user to danger by the hoist, chain or load.
- Do not allow the load to swing.
- To avoid side pull, lowering and lifting should only be carried out when the load chain forms a straight and vertical line between the load and lifting attachment point.
- Only use this product when all leveling feet have been deployed and leveled.
- Ensure the hub is leveled before inserting the Davit.
- The base castors are for positioning only and not to be loaded during operation.*



- Always make sure the basket is engaged and secured to the tail of the base before any lift.*
 - Always make sure the correct amount of weight is in the counterbalance basket before any lift.*
 - When using the Counterbalance Trailer Hitch make sure the system has been levelled and the ball hitch is fully engaged and secured.**
 - Ensure that the vehicle has a European type approved 2"ball hitch tow bar and has a rating that can withstand a minimum load of 612kg [6kN].**
 - The vehicle must weigh a minimum of 2000kg.**
- * Only applicable to the Counterbalance system.
 **Only applicable to the Counterbalance Trailer Hitch.

Warning

- The equipment should not be used outside of its limitations, or for any purpose other than that for which it is intended.
- Do not lift or transport loads while personnel are in the danger zone.
- Do not allow personnel to pass under a suspended load.
- Never leave a suspended load unattended.
- Be aware of hazards when setting up/folding down, such as trapping fingers in rotating parts.
- Be aware of any adverse weather conditions such as strong or gusty winds which could impose additional horizontal loads and affect the stability of the structure. Stop using if weather is impacting on lifting, and either disassemble the system or tie it to a rigid structure to ensure it can't overturn.
- Don't allow the load to hit the system.
- Under no circumstances should the product be moved under load.
- Do not lift a load outside the permissible operating radius (Refer to figure A, B & C).
- Under no circumstances remove any weights from the basket during a lift.*

* Only applicable to the Counterbalance system

Allowable Rotation

H Base: The operating radius for the H Base is within the inside of the legs of the base 90°, for the lifting of goods, personnel and fall arrest. When loaded the Davit is not to be rotated outside of the area indicated in the image below. The image and table below indicates the operating radius for the H Base.

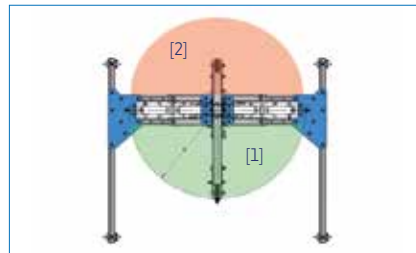

PORTABASE® H Base			
Area	Goods Lifting	Personnel Lifting	Fall Arrest
Green Area [1]	✓	✓	✓
Red Area [2]	x	x	x

Counterbalance: The allowable operating area for the Counterbalance is dependent on the application in which it is being used. For goods and personnel lifting the allowable area of rotation is 270°.

For fall arrest applications the allowable working area is 45° on each side from the centre of the base.

Depending on the application the Davit is not to be rotated outside of the areas indicated in the image below. The image and table below indicates the operating radius for the Counterbalance.

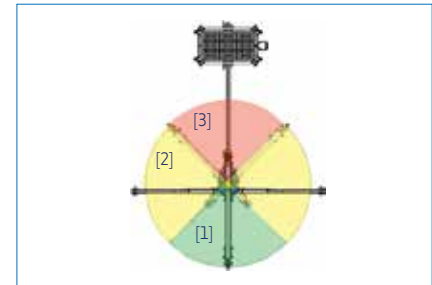

PORTABASE® Counterbalance			
Area	Goods Lifting	Personnel Lifting	Fall Arrest
Green Area [1]	✓	✓	✓
Yellow Area [2]	✓	✓	x
Red Area [3]	x	x	x

➤ Correct Operation

Counterbalance Trailer Hitch: The allowable operating area for the Counterbalance Trailer Hitch is dependent on the application in which it is being used. For goods and personnel lifting the allowable area of rotation is 270°.

For fall arrest applications the allowable working area is 45° on each side from the centre of the base.

Depending on the application the Davit is not to be rotated outside of the areas indicated in the image to the right. The image and table indicates the operating radius for the Counterbalance Trailer Hitch.

The following must be considered when using a Counterbalance Trailer Hitch:

- When using the Counterbalance Trailer Hitch make sure the system has been levelled and the ball hitch is fully engaged and secured.
- Ensure that the vehicle has a European type approved 2"ball hitch tow bar and has a rating that can withstand a minimum load of 612kg [6kN].
- The vehicle must weigh a minimum of 2000kg.

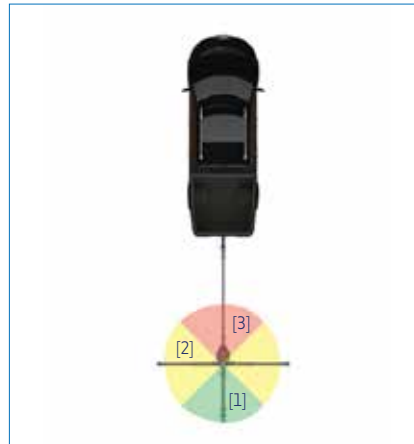

PORTABASE® Counterbalance Trailer Hitch			
Area	Goods Lifting	Personnel Lifting	Fall Arrest
Green Area [1]	✓	✓	✓
Yellow Area [2]	✓	✓	x
Red Area [3]	x	x	x

Permissible Orientation

Counterbalance Trailer Hitch: The Trailer Hitch Connector can be attached parallel or perpendicular to the rear of the vehicle.

Please see example images below of how to attach the Trailer Hitch to the vehicle.

*Note: This is only applicable with the PORTABASE® Counterbalance Trailer Hitch variant.



Parallel



Perpendicular

Fall Protection

This section must not be read in isolation from all other sections of this manual. Read the whole manual before using this product.

Fall arrest: This product is tested and conforms to the requirements of EN795:2012 Personal Fall Protection Equipment – Anchor Devices subject to the configuration of the product and the Davit being used.

When being used for fall arrest purposes, the operator must use a body harness and a shock absorber that complies with the relevant national standards and regulations and that limits the maximum allowed force (m.a.f.) to 6kN.

Each personnel lift must be properly planned, and all weights clearly known along with a clear understanding of the WLL and constraints of all personal fall arrest system components.

The capabilities stated in the table below apply to standard range systems only. If unsure about your system consult serial labels, information filled in on page 38 or consult your supplier. Custom versions of the system are available tailored to specific lifting needs. These versions are designated with a 'C' at the end the product number on the serial label attached to each product.

Davit Radius	Counterweight Required [kg]
	EN795
800mm	360kg
1000mm	360kg



The system is not suitable for fall arrest applications.



The system is suitable for fall arrest applications. Specify number of users. Max weight of 150kg.

Additional Notes for Correct Operation & Warnings

- Always carry out pre-use checks before using this equipment. It is advised to use a buddy system and inspection must be by a competent person.
- Never walk away from the footprint of the product or move outside designated safe zones whilst connected to it where there is a risk of a fall.
- When using the product as a fall arrest anchor ensure there is adequate fall clearance when working at height. A competent person should calculate this, taking in to account all of the components of the personal fall arrest system.
- Always consider the potential effects of sharp edges, chemical reagents, electrical conductivity, cutting, abrasion, climatic exposure on all components of the fall protection system, and the effect of offset forces as a result of pendulum falls.
- Ensure the structure on which the product is mounted is horizontal enough to get it to be level (check bubble indicator) after the feet are adjusted.
- If the product has been subjected to a fall arrest or impact force it must be immediately removed from service.
- The substrate of the structure on which the

➤ Fall Protection Applications

product is placed must be able to sustain the loads specified for the device in all orientations permitted, including a safety factor of at least 2.

- Never exceed the number of allowable users.
- Never adjust the product whilst a person is attached to it.
- Only use designated anchor points for the attachment of fall protection devices.
- Ensure that any fall protection system components being used are compatible and meet the requirements of applicable standards.
- When using this product ensure that there is a rescue plan prior to starting work and ensure that users are trained in the correct execution of the plan and have all necessary rescue equipment to hand.
- Where required by regulation, each installation must be approved by a qualified person.
- Always wear appropriate PPE when installing, setting up, dismantling and using this equipment.
- Misuse of this product could result in serious injury or death.

Warning

- For fall protection applications the maximum user weight is 150kg or the weight allowed by the lowest rated piece of equipment in the fall arrest system.
- Ensure that you have read and understood the maximum force tables for each anchor point on the corresponding davit selected to be used with the Porta Base. This varies (is reduced) as the Davit radius increases.
- When using for fall protection, only use one fall arrest device with each pulley/sheave and make sure they never cross paths with each other.
- When using the product in conjunction with another manufacturers fall protection products, ensure that you have read the instructions for use of those products to ensure their suitability and any restrictions for use. Only use approved brackets for the connection of winches and self retracting lifelines.

- It is essential for safety that the product is withdrawn from use immediately and not be used again until confirmed in writing by a competent person should;

1. Any doubt arises about its condition for safe use,
2. It has been used to arrest a fall or;
3. It has been used for any other purpose, other than as a component of a personal fall protection system.

IRATA [International Rope Access Trade Association]

This product is suitable for rope access and has been tested to 15kN static load as per test requirements of IRATA international code of practice (ICOP).

Compatible Davit and Fall Protection Force Ratings | PORTX® DAVIT

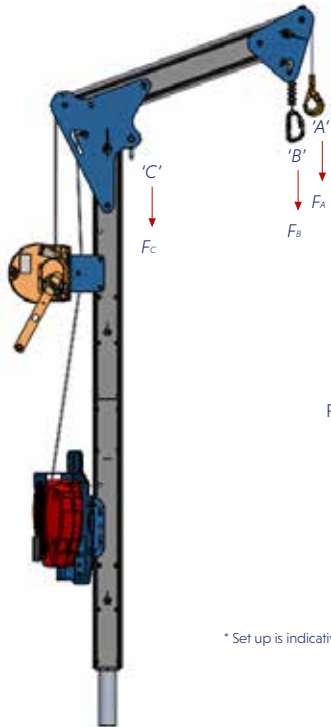

F = Maximum Rated Force

* Set up is indicative

PORTX® DAVIT				
PFAS INFORMATION	Davit Radius	Anchor Point 'A'	Anchor Point 'B'	Anchor Point 'C'
H Base	800 mm	12 kN	12 kN	22.2 kN
Counterbalance	800 mm	12 kN	12 kN	22.2 kN
Trailer Hitch	800 mm	12 kN	12 kN	22.2 kN
Fixed Sockets	800 mm	12 kN	12 kN	22.2 kN

➤ Fall Protection Applications

Compatible Davit and Fall Protection Force Ratings | TDAVIT® Shackled

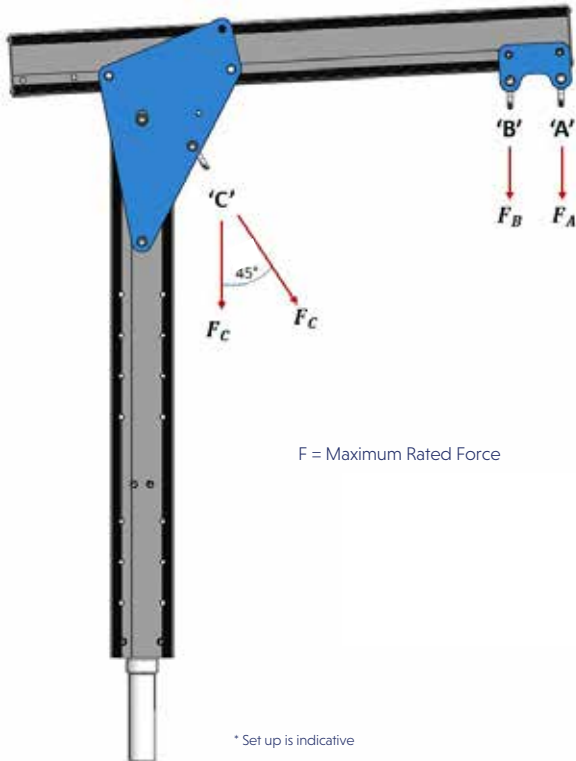

* Set up is indicative

TDAVIT® Shackled				
PFAS INFORMATION	Davit Radius	Anchor Point 'A'	Anchor Point 'B'	Anchor Point 'C'
H Base	800 mm	22.2 kN	22.2 kN	22.2 kN
Counterbalance				
Fixed Sockets				
Counterbalance	< 1000 mm	16 kN	16 kN	22.2 kN
Fixed Sockets				
Trailer Hitch				
Fixed Sockets	< 1200 mm	16 kN	16 kN	22.2 kN
Fixed Sockets	< 1600 mm	15 kN	15 kN	22.2 kN

Compatible Davit and Fall Protection Force Ratings | TDAVIT® Winched

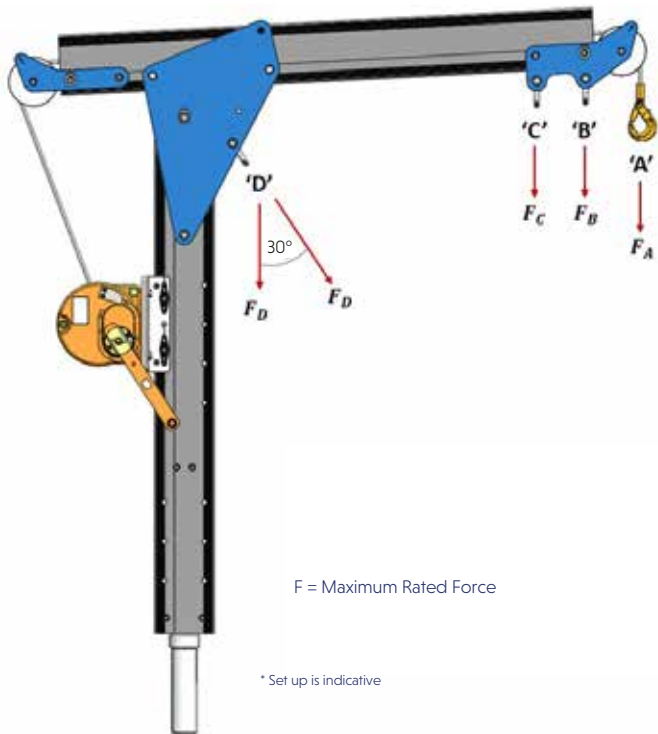

F = Maximum Rated Force

* Set up is indicative

TDAVIT® Winched					
PFAS INFORMATION	Davit Radius	Anchor Point 'A'	Anchor Point 'B'	Anchor Point 'C'	Anchor Point 'D'
H Base	800 mm	22.2 kN	22.2 kN	22.2 kN	22.2 kN
Counterbalance					
Fixed Sockets					
Counterbalance	< 1000 mm	16 kN	16 kN	16 kN	22.2 kN
Fixed Sockets					
Trailer Hitch					
Fixed Sockets	< 1200 mm	16 kN	16 kN	16 kN	22.2 kN
Fixed Sockets	< 1600 mm	15 kN	15 kN	15 kN	22.2 kN

➤ Fall Protection Applications

Compatible Davit and Fall Protection Force Ratings | TDAVIT® Double Winched

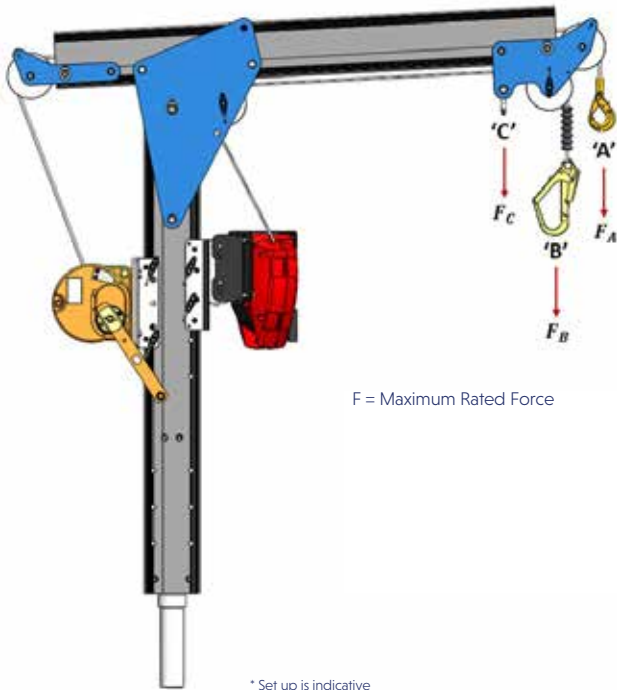

TDAVIT® Double Winched				
PFAS INFORMATION	Davit Radius	Anchor Point 'A'	Anchor Point 'B'	Anchor Point 'C'
H Base	800 mm	22.2 kN	22.2 kN	22.2 kN
Counterbalance				
Fixed Sockets				
Counterbalance	< 1000 mm	16 kN	16 kN	16 kN
Fixed Sockets				
Trailer Hitch				
Fixed Sockets	< 1200 mm	16 kN	16 kN	16 kN
Fixed Sockets				
Fixed Sockets	< 1600 mm	15 kN	15 kN	15 kN

Compatible Davit and Fall Protection Force Ratings | PORTADAVIT^{QUANTUM} Reduced Radius

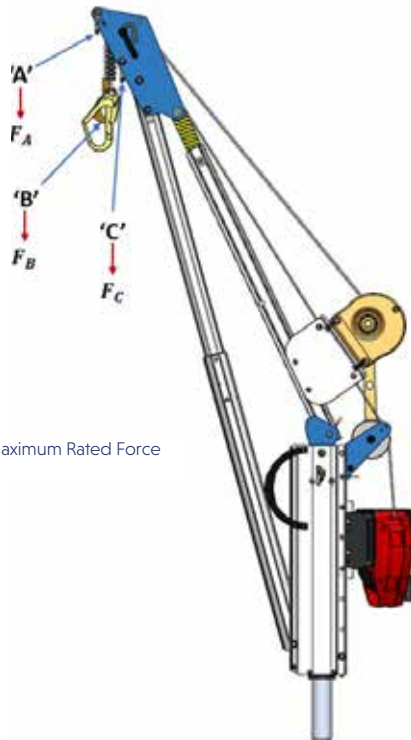

F = Maximum Rated Force

* Set up is indicative

PORTADAVIT ^{QUANTUM} Reduced Radius [PDQRW]				
PFAS INFORMATION	Davit Radius	Anchor Point 'A'	Anchor Point 'B'	Anchor Point 'C'
H Base	800 mm	16 kN	16 kN	16 kN
Counterbalance	800 mm	16 kN	16 kN	16 kN
Trailer Hitch	800 mm	16 kN	16 kN	16 kN
Fixed Sockets	800 mm	16 kN	16 kN	16 kN

› Inspection & Maintenance

The following information is based on REID Lifting's recommendations and does not remove the responsibility of the user to comply with the relevant regulations and standards that are valid in the respective countries and regions where the system is being used.

Before use, the product should be inspected for visual defects using the checklist below:

- › Ensure all welds on the hub are free of cracks or defects.
- › Ensure levelling feet are not showing any signs of deformation, corrosion or damage.
- › Ensure all adjustment pins are not distorted or damaged. All pins shall be fully engaged before using the product.
- › Ensure all bolts are correctly tightened and free from excessive corrosion.
- › Ensure all leg sections are free from indentation.
- › Ensure the weight basket is retaining all weights.*
- › Ensure the weight basket is fully engaged to the tail before any lift.
- › Ensure the king pin for the Davit is fully engaged in the hub before applying a load.
- › Check the Davit in accordance with its corresponding Assembly & Operation Guide.

*Only applicable to the Counterbalance system.

Inspections are instigated by the user, the above list covers the main components on this product, any accessories and third-party components must be inspected following the corresponding instructions.

Regular Inspections

To ensure that the product's frame remains in safe working order it must be inspected regularly by a competent or qualified person. We recommend inspections every 6 months for personnel lifting and every 12 months for goods only, unless local regulations, adverse working conditions or profile of use and risk dictate shorter periods. The components of the system frame need to be checked for damage, wear, corrosion or other irregularities. It may be necessary to disassemble the system frame in order to do this. Particular attention should be paid to checking the profiles for denting, making sure there is no wear or elongation on the bolt holes and ensuring that the trolley moves freely along the beam.

It is recommended that once inspected or repaired, the device is marked with the date of the next inspection.

Inspections are instigated by the user. If detailed information is required on inspection and test criteria, please contact your supplier's technical department or REID Lifting. The equipment Inspection Record is on page 42.

If using the product in explosive atmospheres, see additional section titled ATEX.

Maintenance & Repair

In order to ensure correct operation, the conditions for inspection and maintenance must be complied with. If any defects are found, stop using the product immediately.

No alterations or additions to the equipment beyond the replacement of standard parts by an authorised representative should be made without the written consent of the manufacturer. Any necessary repairs identified during inspections should only be carried out by an approved specialist workshop using original spare parts. Any repair must be carried out in accordance with the manufacturer's instructions.

It is recommended to maintain the equipment in a clean and dry manner. Cleaning is suggested using a sponge or cloth with warm, soapy water, rinsing and allowing to dry.

This product must be assembled using metric fixings of the same type and quality as those supplied by the original manufacturer only. Failure to do so could have an impact on the structural performance and stability of the product. Reid Lifting and its resellers can supply these spare parts locally.

Storage & Transportation

When transporting the components, take note of all the manual handling considerations.

Do not throw the product down or stack any items on top of it.

Always place carefully and securely on the ground to avoid damaging the equipment.

This product can be manufactured for use in explosive atmospheres in line with the following requirements and information as an upgrade. Any use which differs or exceeds this is considered incorrect and REID Lifting Ltd will not accept any responsibility or liability for damages resulting from false application. The risk is solely with the user. If the product has been customized in any way, then it may not comply with standards and no longer be suitable for use in explosive atmospheres. If this is the case, then the product will not have any of the markings below. If in doubt, please contact your REID representative.

ExVeritas Certification

- > ATEX - ExVeritas 23ATEX1623X
- > UKEX - ExVeritas 23UKEX1624X

Classification [Zone 2]

This product may meet the requirements of Category 3 equipment for use in Zone 2 explosive atmospheres, providing a normal level of protection where mixtures of air and gases, vapours or mists or by air and dusts mixtures are unlikely to occur or, if they do occur, are likely to do so only infrequently and for a short period only.

If the product is suitable for use in this environment it will have the following identification on the serial label:

As Standard for Zone 2 Environments:

 II 3 GD
 Ex h IIC T6 Gc
 Ex h IIIC T85°C Dc
 Tamb -20°C to +55°C



Spark Formation

There is an Increased danger of ignition when certain material pairings clash, namely non-corrosion-resistant steel or cast iron against aluminium, magnesium or pertinent alloys. This applies especially in the case of rust or surface rust. When assembling the product and inserting fastening components, these must therefore be clear of rust and debris of any kind. As stated previously, care must be taken to ensure the product is handled in a suitable manner, never thrown down and always placed carefully onto the ground.

Static Electricity

For Zone 2 applications, there is a potential risk of static electricity build-up leading to an incentive spark. To mitigate the risk powder coated sections will be removed to ensure the product has a clear route to earth. Although the risk of such ignition is unlikely, it is the user's responsibility to ensure that the route to earth is maintained.

Inspection, Maintenance & Repair

Special attention should be given to dust deposits on the structure, especially in areas where the profiles come into contact, and should be wiped clean and care taken not to apply materials that could create electrostatic charging.

The structure is predominantly constructed from aluminium which will not rust. However, there are steel components used throughout.

Where there is sign of any rust deposits on the aluminium structure, it should be wiped clean as above and, where there is sign of rust on a steel component, that component should be removed from use and the structure not used until a replacement is fitted.

If using this product in explosive atmospheres, in addition to the Regular Inspection and Maintenance information above, these additional instructions should be followed:

- Inspections must be instigated by the user prior to each use if used in a potentially explosive atmosphere.
- Inspections and maintenance must be carried out at a safe distance away from an explosive atmosphere.

► Assembly Instructions | H Base

The **PORTA**BASE® H Base and its constituent components are described in the image below.

The H Base system will be delivered in three components which are the Left Leg Assembly, Right Leg Assembly and Central Hub.

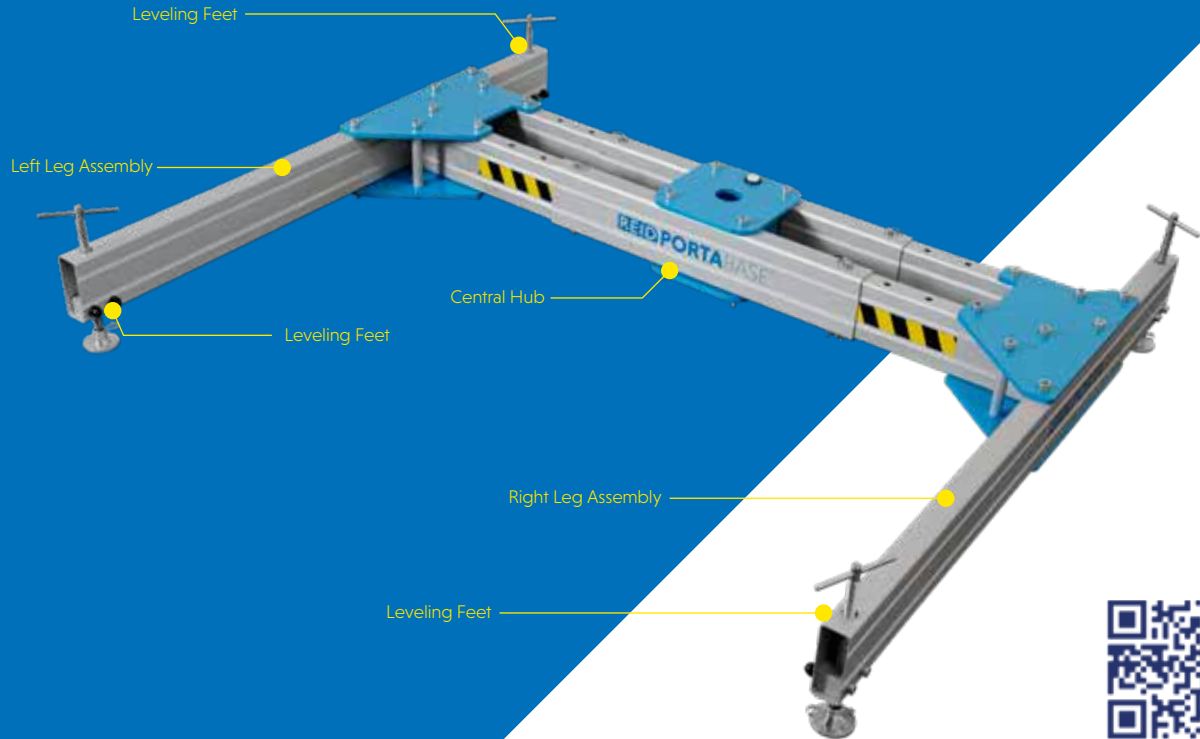

Appropriate PPE should be worn: ► Gloves ► Protective Footwear ► Hard Hat

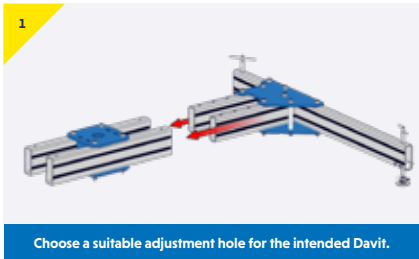

› Insert the first Leg Assembly into the Central Hub.

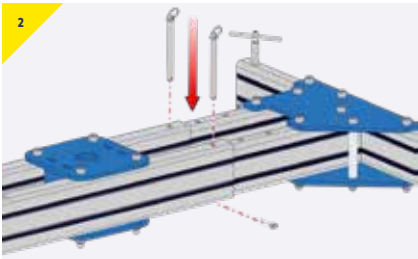

› Repeat steps 1 - 2 for the second Leg Assembly, securing the Leg Assembly to the Central Hub.

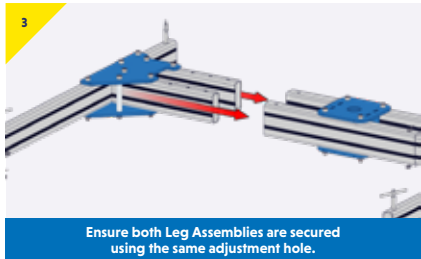

› Repeat steps 1 - 2 for the second Leg Assembly, securing the Leg Assembly to the Central Hub.

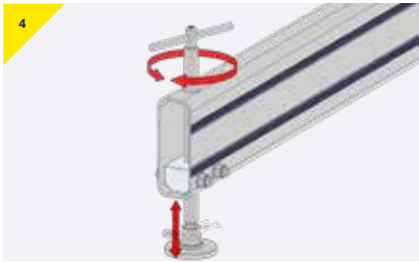

› Level the hub by adjusting the leveling feet and check against the spirit level on the top of the Central Hub.

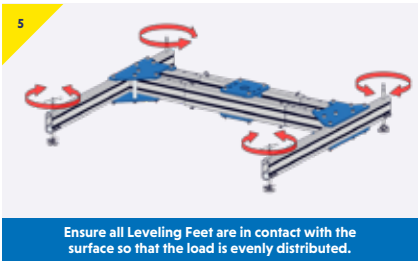

› Repeat step 4 for each of the Leveling Feet.

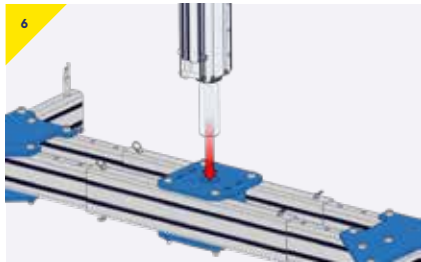

› Insert the Davit into the Central Hub for use.

NB. Please refer to the Assembly & Operation Guide of the applicable Davit system when used in conjunction with the PORTABASE®.

➤ Assembly Instructions | Counterbalance

The **PORTA**BASE® Counterbalance and its constituent components are described in the image below.

The Counterbalance system will be delivered in five components which are the Left Leg Assembly, Right Leg Assembly, Central Hub, Tail and Basket.

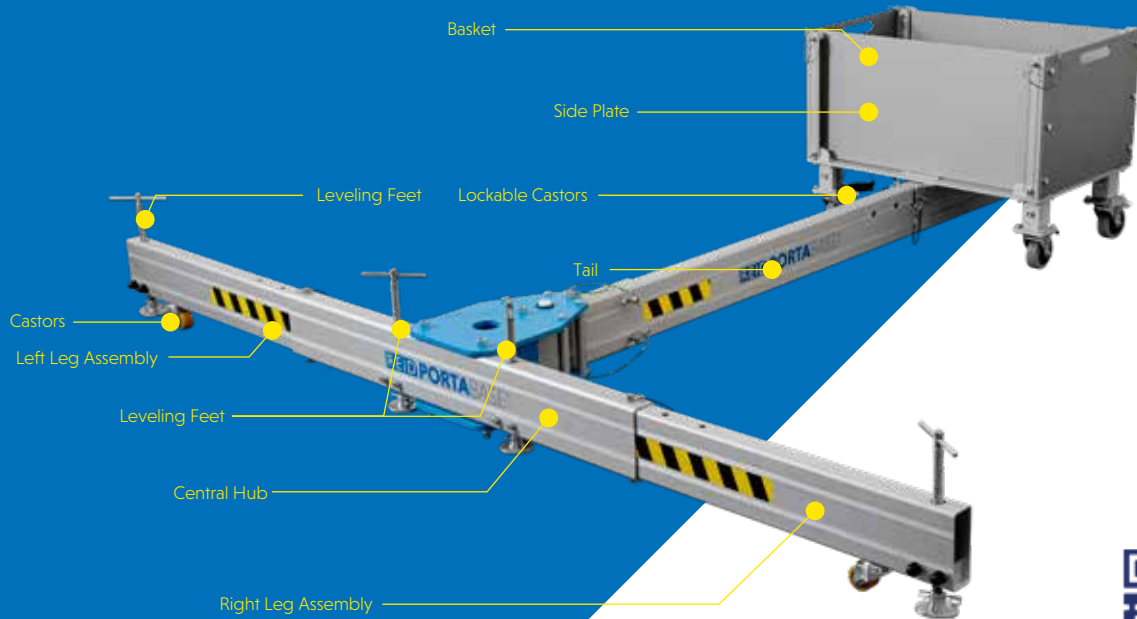

Appropriate PPE should be worn: ➤ Gloves ➤ Protective Footwear ➤ Hard Hat

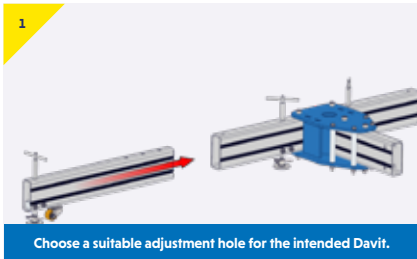

- Insert the first Leg Assembly into the Central Hub.

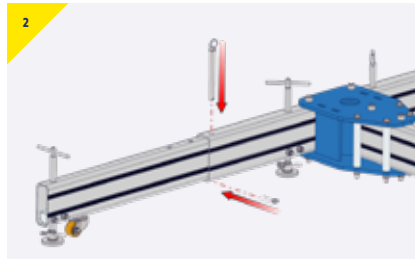

- Insert the clevis pin and secure into position with the R-clips provided.

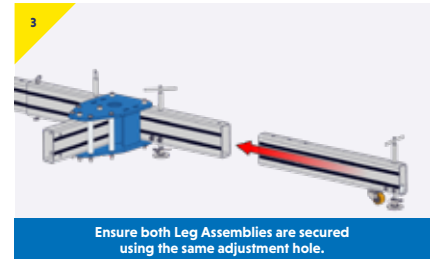

- Repeat steps 1 and 2 for the second Leg Assembly, securing the Leg Assembly to the Central Hub.

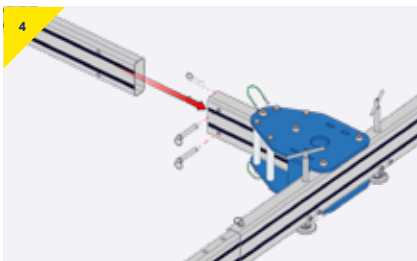

- Insert the Tail into the Central Hub and secure with the clevis pin and R-Clip provided.



- Remove the pins from each side to unfold the basket.

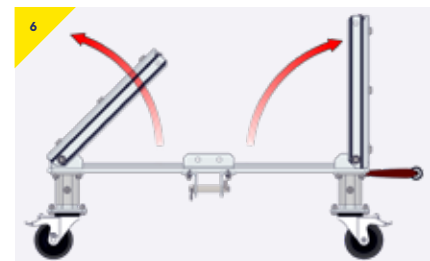

- Unfold each end of the basket.

➤ Assembly Instructions | Counterbalance

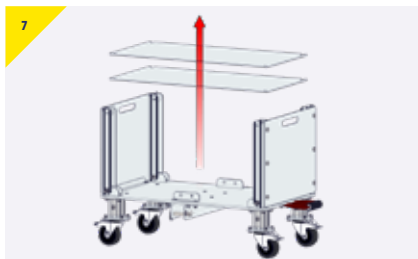

- Remove the first side plate from the storage position at the bottom of the basket.

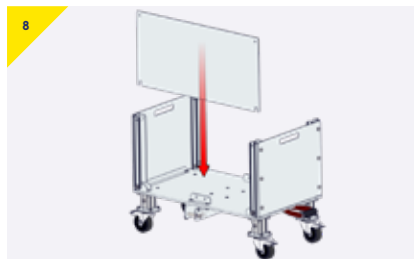

- Insert the first side plate between the end plate channels.



- Ensure the side plate sits correctly over the pin.

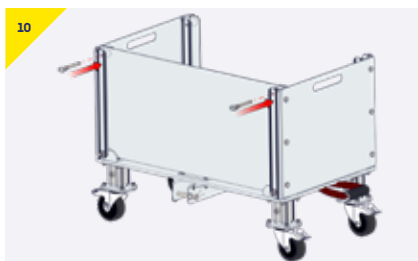

- Secure in place with the pins.



- Repeat steps 7 - 10 for the second side plate.

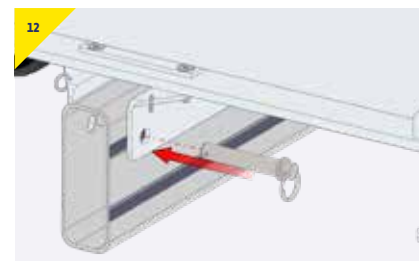

- Attach the basket to the tail and secure both sides with pins.

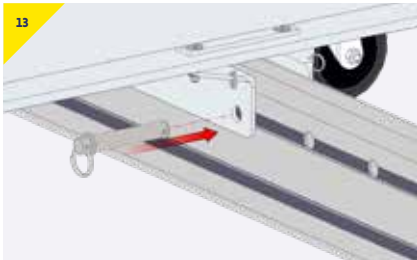

- Ensure the pins are fully engaged on both sides.



- Castors are for positioning purposes only and not suitable for loading.**
- Level the hub by adjusting the leveling feet and check against the spirit level on the top of the Central Hub.

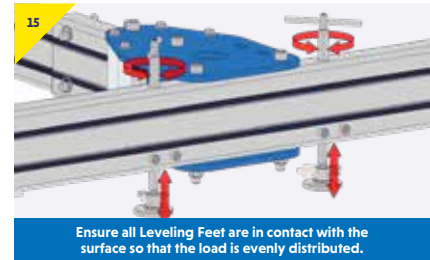

- Ensure all Leveling Feet are in contact with the surface so that the load is evenly distributed.**
- Repeat step 14 for each of the Leveling Feet.



- Insert the Davit into the Central Hub for use.

NB. Please refer to the Assembly & Operation Guide of the applicable Davit system when used in conjunction with the PORTABASE.

▶ Assembly Instructions | Trailer Hitch

The **PORTABASE**® Counterbalance Trailer Hitch and its constituent components are described in the image below.

The Counterbalance system will be delivered in five components which are the Left Leg Assembly, Right Leg Assembly, Central Hub, Tail and Trailer Hitch Connector.

Appropriate PPE should be worn: ▶ **Gloves** ▶ **Protective Footwear** ▶ **Hard Hat**

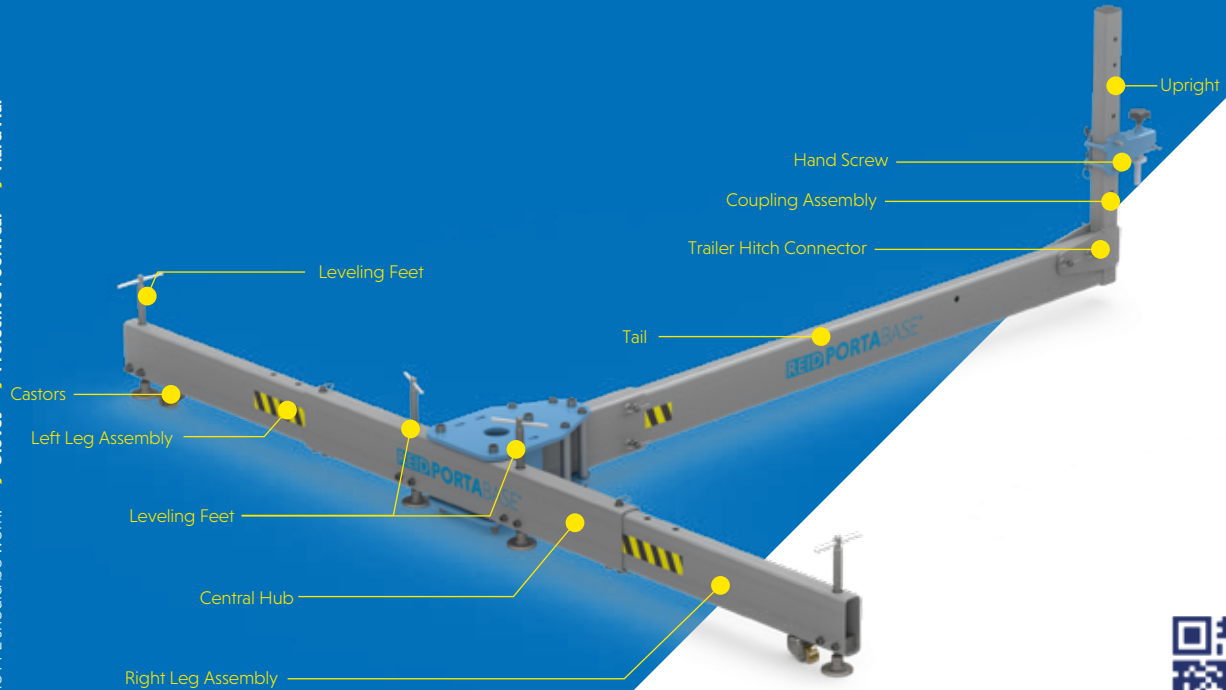

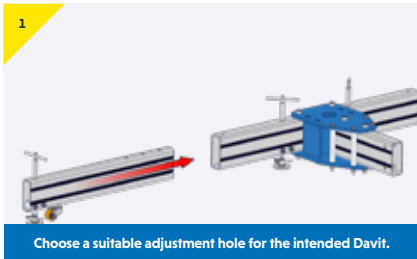

1

Choose a suitable adjustment hole for the intended Davit.

- Insert the first Leg Assembly into the Central Hub.

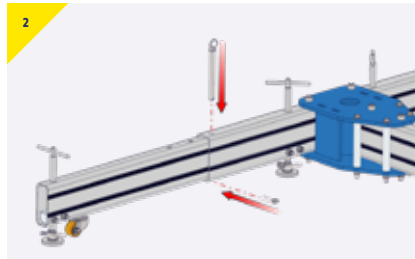

2

- Insert the clevis pin and secure into position with the R-clips provided.

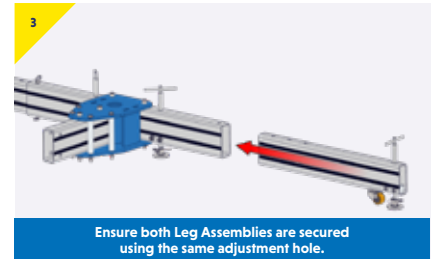

3

Ensure both Leg Assemblies are secured using the same adjustment hole.

- Repeat steps 1 and 2 for the second Leg Assembly, securing the Leg Assembly to the Central Hub.

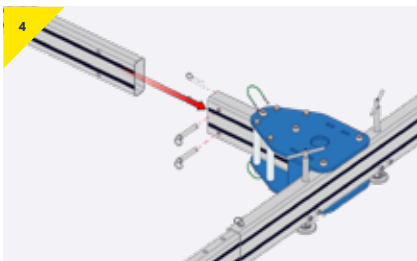

4

- Insert the Tail into the Central Hub and secure with the clevis pin and R-Clip provided.



5

- Insert the coupling assembly onto the upright.



6

- Secure the coupling assembly at the desired height using ball lock pins provided.

➤ Assembly Instructions | Trailer Hitch



- Release the hand screw to attach to the vehicle.



- Present the Trailer Hitch Connector to the vehicle ball hitch.

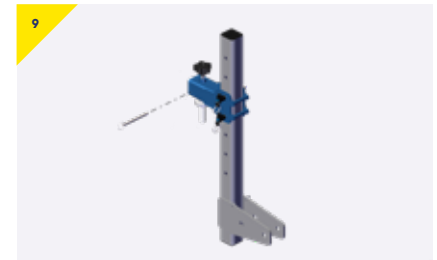

- Insert the pin provided behind the ball hitch.

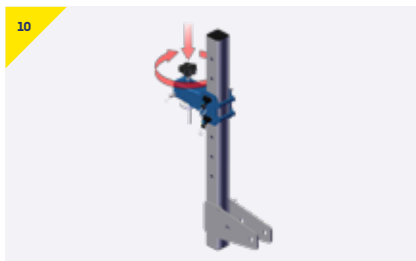

- Fasten down the hand screw to clamp the ball hitch.

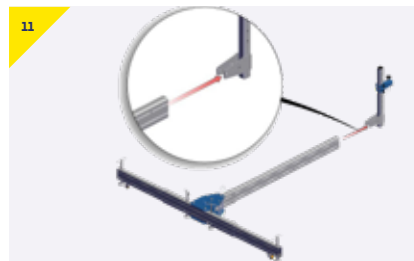

- Align the Counterbalance to the upright.

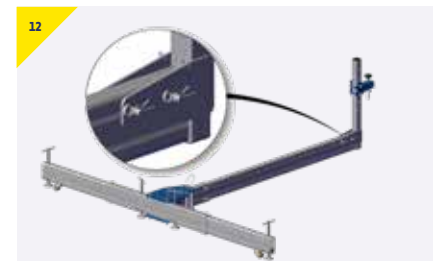

- Attach the upright to the tail using the pins and R-clips provided.

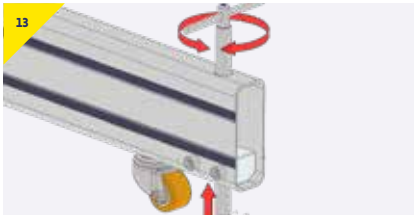

Castors are for positioning purposes only and not suitable for loading.

- > Level the hub by adjusting the leveling feet and check against the spirit level on the top of the Central Hub.

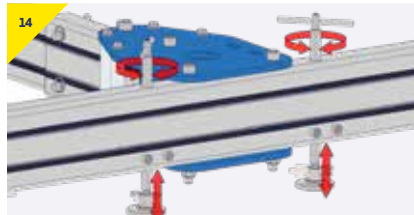

Ensure all Leveling Feet are in contact with the surface so that the load is evenly distributed.

- > Repeat step 13 for each of the Leveling Feet.

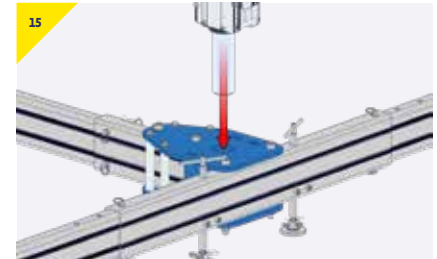

- > Insert the Davit into the Central Hub for use.

NB. Please refer to the Assembly & Operation Guide of the applicable Davit system when used in conjunction with the PORTABASE.

➤ Variants & Options

Height Adjustable Feet

Height adjustable feet can be fitted to the PORTABASE Counterbalance weight basket. This provides additional fine height adjustment [up to 230mm].

Each foot may be adjusted independently, providing a method of levelling the system on uneven ground.

- Attach the Height Adjustable Feet to the basket and secure with the bolts provided as shown in figure 1.

If the weight basket's height adjustable feet are fitted the following points must be observed:

- When maneuvering the weight basket, always have the height adjustment legs fully retracted as shown in figure 2.
- Position the system in place for the lift before setting the height
- Manually raise each leg in turn and set the height by rotating the handle in a clockwise motion.
- Having set the adjustment of all four legs on the basket, ensure that the system is level prior to use.

Inspection & Maintenance

The legs and brackets should be subjected to periodic inspections by a competent person in line with products inspection and maintenance guidelines.

The height adjustable feet should be lubricated with EP2 grease on the thread at regular intervals [up to a 6 months maximum], depending on service conditions.

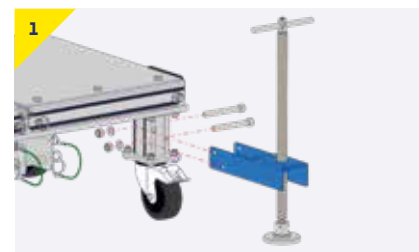

Height Adjustable Feet in parked position



Operate the Height Adjustable Feet to the required height

PORTABASE® H Base

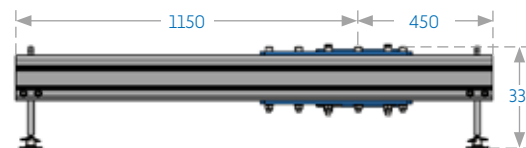
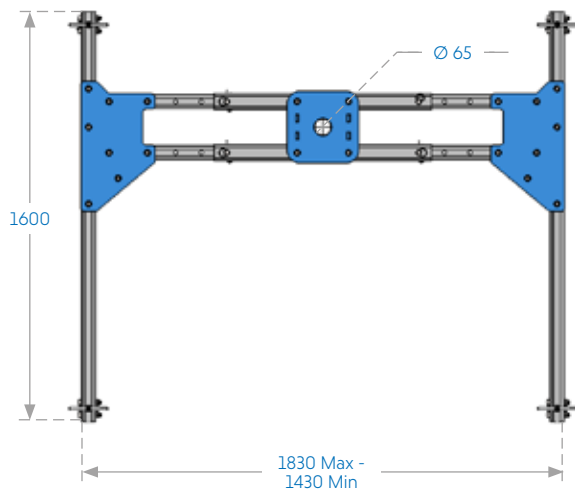

All dimensions in mm.

> Dimensions

PORTABASE® Counterbalance

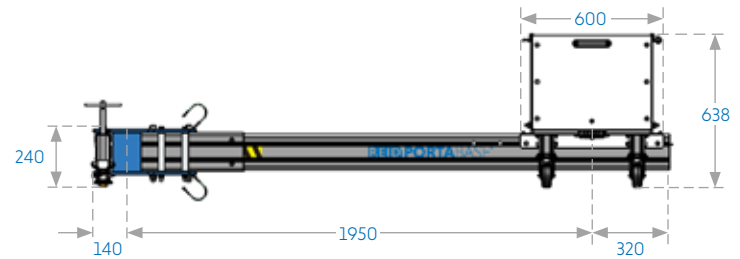
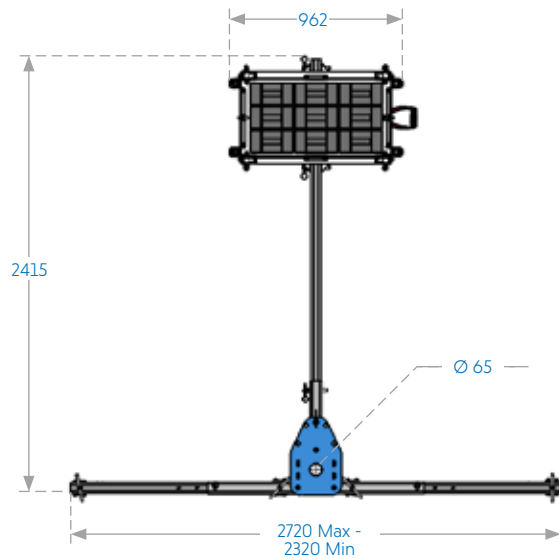

All dimensions in mm.

PORTABASE® Counterbalance Trailer Hitch

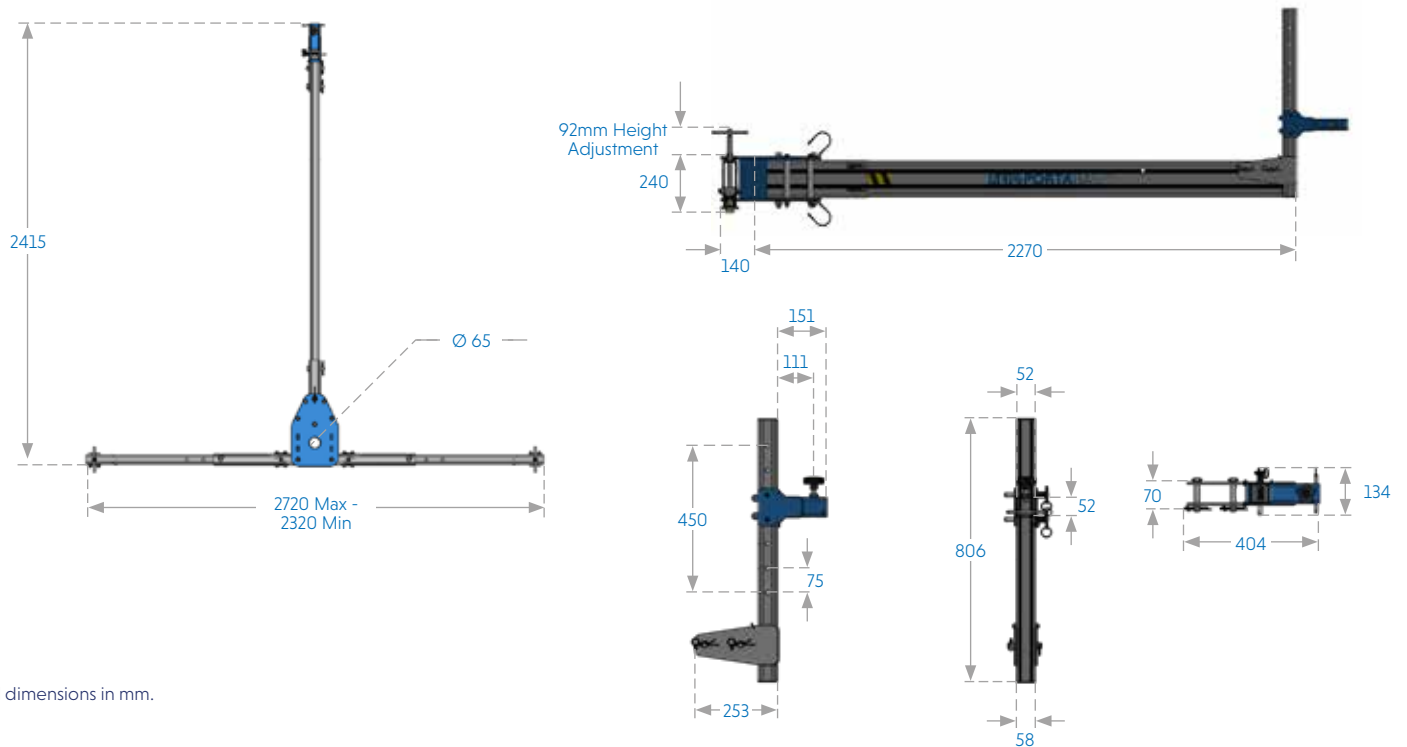

All dimensions in mm.

› Quality & Safety

Regulations, Standards & Directives

This product complies with the following:

- › ATEX Directive - 2014/34/EU*
- › Machinery Directive 2006/42/EC
- › PPE Regulation (EU) 2016/425
- › The Provision and Use of Work Equipment Regulations 1998 (S.I. 1998 No. 2306)
- › The Lifting Operations and Lifting Equipment Regulations 1998 (S.I. 1998 No. 2307)
- › In conformity with EN795:2012 and OSHA 1926.502(d)(15)

*Powder coated sections removed

It is essential to adhere to the safety regulations of the respective country for using manual lifting equipment.

Accreditations

Quality and Safety are at the heart of the REID Lifting ethos and we are committed to maintaining the very highest standards. With this in mind, we have undertaken external accreditations to ensure we stay focused on what is important to our clients and users, and ahead of market trends and developments.

REID Lifting is continuously audited by Lloyds Register Quality Assurance (LRQA) for approval of its Integrated Management System combining quality systems management, environmental issues and the health and safety practices within the company.

- › ISO 9001:2015 - Quality management system which assesses an organization's ability to consistently provide products that meet customer and applicable regulatory requirements and aims to enhance customer satisfaction.
- › ISO 14001:2015 - Specifies the requirements for implementing environmental management systems throughout all areas of the organization.
- › ISO 45001 – Health & Safety Management System

- › LEEA Membership - REID Lifting is a full member of the Lifting Equipment Engineers Association (LEEA membership 000897). REID Lifting conforms to the main aims of the association which is to achieve the highest standards of quality and integrity in the operations of members. Entry qualifications are demanding and strictly enforced through technical audits based on the Technical Requirements for Members.
- › IRATA - REID Lifting is an associate member of the Industrial Rope Access Trade Association (IRATA International membership number 148). REID Lifting works in accordance with the IRATA Code of Practice and, in doing so, contributes to promote the development of safe systems.

Conformité Européenne [CE] & UK Conformity Assessed [UKCA]

REID Lifting's products have been designed, tested and approved (as appropriate) by the Conformité Européenne and UK Conformity Assessed. This certifies that REID Lifting's products meet the demands of the European and UK Directives and Regulations regarding Health and Safety requirements. The EC type-examination for this device has been carried out by SGS United Kingdom Ltd, 202b, Worle Parkway, Westonsuper-Mare, BS22 6WA, United Kingdom (CE body no.0120) in accordance with Module B of the PPE Regulation. The EC quality assurance system for this device has been carried out by SGS Fimko Oy, Takomotie 8, FI-00380 Helsinki, Finland. (CE body no. 0598) and SGS United Kingdom Ltd, 202b, Worle Parkway, Weston-super-Mare, BS22 6WA, United Kingdom (CE body no.0120) in accordance with Module D PPE Regulation (EU) 2016/425 and as brought into UK law and amended.

Testing

Testing and technical file review are integral parts of our design and manufacturing process. External verification of products is undertaken where appropriate, using government approved Notified Bodies.

All products have been thoroughly type tested. Each product is supplied with a certificate of conformance and individual record of thorough examination or test.

Language

It is essential for the safety of the user that if this product is re-sold outside of the original country of destination, the reseller shall provide instructions for use, maintenance, inspection and repair in the language of the country where it will be used.

Product IPR

Intellectual property rights apply to all REID Lifting Ltd products. There are patents in place, or pending, for:

PORTAGANTRY* | **PORTA**GANTRY^{RAPIDE} |
PORTADAVIT^{QUANTUM} | **T**DAVIT*

All product names are trademarks of REID Lifting Ltd:

PORTAGANTRY* | **PORTA**GANTRY^{RAPIDE} |
PORTADAVIT* | **PORTA**BASE | **T**DAVIT* |
PORTAQUAD* | **PORTX**™

➤ Product Labelling Key

Safety Labels



Insert and secure the bolt before loading the system.



Insert the detent pin and fully engage before loading the system.



Insert the clevis pin and secure with the clip before loading the system.



Restraint point only.



Read the operational manuals before using the system.



Ensure the pin is fully engaged.

Serial Labels

1. Product Number
2. Serial Number
3. WLL
4. Year of Manufacture
5. Standards
6. ATEX
7. Max Moment



The system is not suitable for fall arrest applications.



The system is suitable for fall arrest applications. Specify number of users. Max weight of 150kg.

PORTA[®]BASE[®] H Base

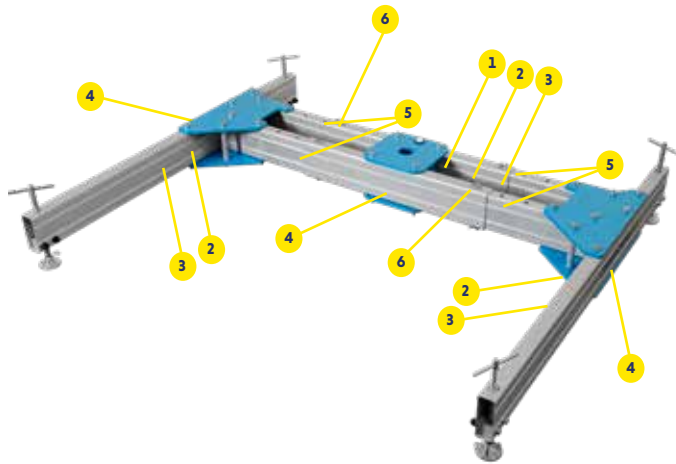

Product labelling

The following labels must be present on the product and must be legible.

1

2

3

4

5

6

➤ Product Labelling

PORTABASE® Counterbalance

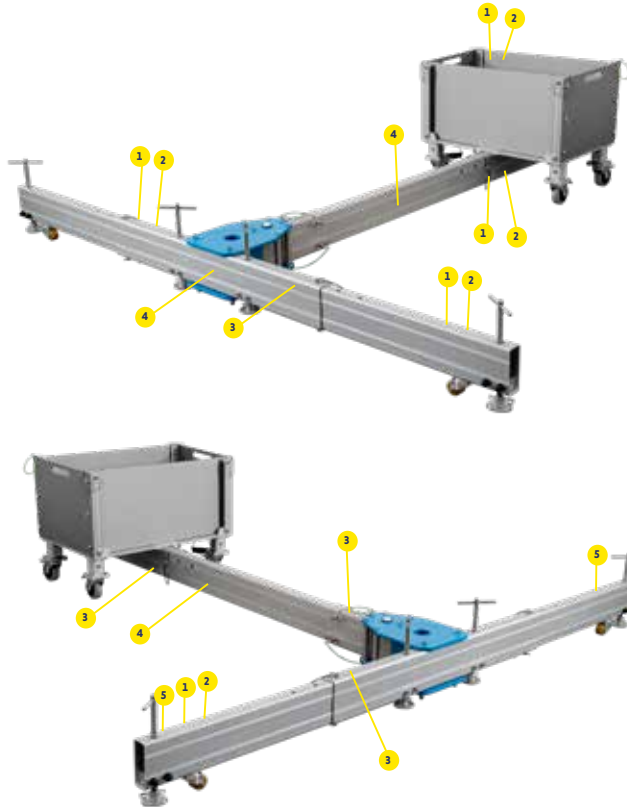

Product labelling

The following labels must be present on your system and must be legible.



PORTABASE® Counterbalance Trailer Hitch

Product labelling

The following labels must be present on your system and must be legible.

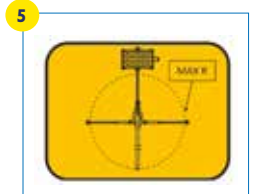
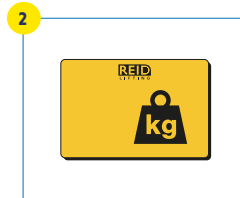
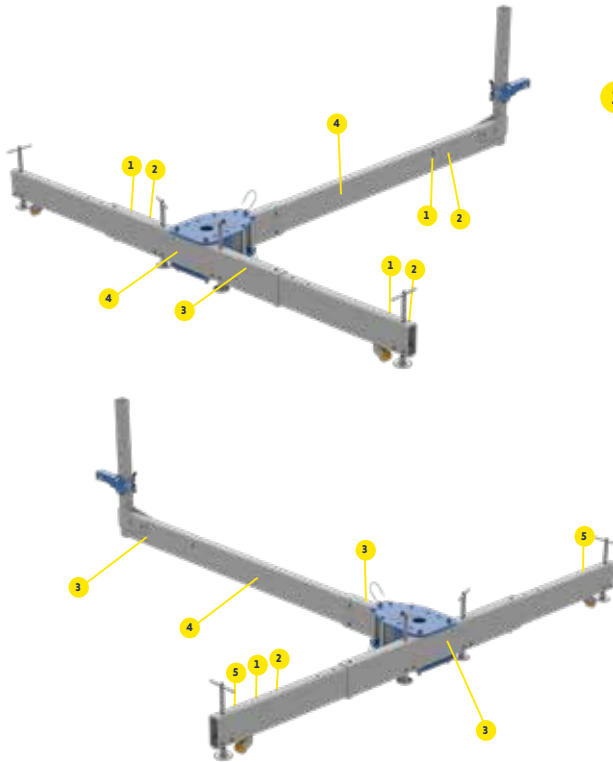

➤ Product Identification & Inspection Record



Marking

The serial labels indicate:

- The product identification number
- The product's unique serial number
- The goods' capacity (WLL) of the device
- The year of manufacture
- The standards to which the device is approved
- The ATEX rating of the product (if applicable)
- CE Marking
- Minimum braking load (MBL)

Insert data from serial numbers found on product into table here:

Contact Us

Head Office, UK

Unit 1 Wyeview
Newhouse Farm Industrial Estate
Chepstow
Monmouthshire
NP16 6UD
United Kingdom

-  +44 (0)1291 620 796
-  enquiries@reidlifting.com
-  www.reidlifting.com

All information herein is copyright protected by REID Lifting Ltd. All company and product names are Trade Mark and Trade Name protected and all REID Lifting Ltd. Product IPR is protected under Patents, Patents Pending and/or Design Rights.



Printed using environment friendly processes and materials.